

## Operating Instructions

Model Name	Model No.
<b>Video Intercom System</b>	<b>VL-SV70</b>

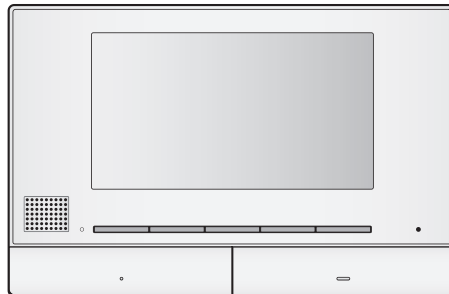

Thank you for purchasing a Panasonic product.  
Please read this document before using the product and save it for future reference.  
Carefully read the information found in the section titled "For your safety" in particular.

This system is not designed to provide complete protection from property loss. To the maximum extent permitted by applicable law, Panasonic will not be held responsible for any damage incurred as a result of property loss.

**Installation Guide is supplied separately.**

**1. Introduction**

**Introduction**

1.1 Model composition .....3  
1.2 Accessory information .....3  
1.3 Additional/replacement accessories .....3  
1.4 General information .....4  
1.5 Symbols, expressions, and styles .....5  
1.6 Trademarks and registered  
trademarks .....5

**2. Important information**

**Important information**

2.1 For your safety .....6  
2.2 Important safety instructions .....6  
2.3 For best performance .....6  
2.4 Other important information .....7  
2.5 Environmental Information (India  
only) .....7

**3. Preparation**

**Preparation**

3.1 Controls .....9  
3.2 Using the display .....11  
3.3 Setting the language, date and time .....11  
3.4 Wide/zoom settings and zoom position  
settings .....12

**4. Talking and monitoring**

**Talking and monitoring**

4.1 Answering doorphone calls .....13  
4.2 Monitoring the outside with the  
doorphone .....13

**5. Recording and playing**

**Recording and playing**

5.1 Recording doorphone images .....14  
5.2 Playing recorded images .....14

**6. Using electric locks and doorbells**

**Using electric locks and doorbells**

6.1 Using electric locks .....16  
6.2 Doorbells .....16

**7. Additional functions**

**Additional functions**

7.1 Zooming in and out (wide/zoom, pan/  
tilt) .....17  
7.2 Sound and display settings for calls and  
monitoring .....17  
7.3 Ringtone settings .....18  
7.4 Main monitor - function settings list .....18

**8. General information**

**General information**

8.1 Cleaning .....20



8.2 Specifications .....20

**9. Troubleshooting**

**Troubleshooting**

9.1 Troubleshooting .....21

## 1.1 Model composition

Model composition	<b>Main Monitor Station (Main monitor*1)</b> 	<b>Door Station (Doorphone*1)</b> 
VL-SV70	VL-MV70	VL-V522L

\*1 Product names used in this document.

### Caution:

- Before attempting to connect or operate this product, please read the nameplate on the bottom or rear of the product.

## 1.2 Accessory information

### 1.2.1 Supplied accessories

#### Note:

- Accessories for installing the main monitor and the doorphone are described in the supplied Installation Guide.

## 1.3 Additional/replacement accessories

Please contact your Panasonic dealer for sales information.

### As of November, 2020

Accessory item	Order number	Number of devices that can be connected
Door Station (referred to as "doorphone" in this document)	VL-V555 (surface mount)	Max. of 1
	VL-V554 (surface mount)	
	VL-V554U (flush mount)	
	VL-V522L (surface mount)	

#### Note:

- The specifications differ depending on the models of doorphone. The following functions are not available for the VL-V522L (supplied doorphone).
  - VL-V522L: Wide/zoom settings and zoom position settings (page 12)

# 1. Introduction

---

## 1.4 General information

- In the event of problems, you should contact your equipment supplier in the first instance.
- After removing the product and any included items from the packaging, store, dispose, or recycle the packaging as necessary. Note that certain types of packaging may be a suffocation or choking hazard.
- The available products differ depending on your region. For more information, please consult your dealer.
- In this document, the suffix of each model number (e.g., the "BX" in "VL-SV70BX") is omitted unless necessary. When the suffixes are used to describe models (e.g., "BX models"), the suffixes refer to all models in the series.
- All the functions listed in this document are available for the supplied main monitor. However, the functions available for the doorphone differ depending on the model of the doorphone. For more information about optional doorphone, see "1.3 Additional/replacement accessories" on page 3.
- Design and specifications are subject to change without notice.
- The illustrations in the supplied document(s) may vary slightly from the actual product.

---

### For Europe

#### For information of Compliance with EU relevant Regulatory Directives, Contact to Authorised Representative:

Panasonic Testing Centre  
Panasonic Marketing Europe GmbH  
Winsbergring 15, 22525 Hamburg, Germany  
<https://www.ptc.panasonic.eu/compliance-documents>

#### Ecodesign information

Ecodesign information under EU Regulation (EC) No. 1275/2008 amended by (EU) Regulation No. 801/2013.

"ErP Free Web Product Information" is available at the following URL:













<https://www.ptc.panasonic.eu/compliance-documents>

Power consumption in networked standby and guidance are mentioned in the Web site above.

This device is classified as a HiNA device (networked equipment with high network availability), according to Ecodesign requirements.

---

### Graphical symbols for use on equipment and their descriptions

1		2		3		4		5		6	
7		8		9		10		11		12	

1. Alternating current (A.C.) 2. Direct current (D.C.) 3. Protective earth 4. Protective bonding earth 5. Caution: risk caused by visible radiation 6. For indoor use only 7. Class II equipment (equipment in which protection against electric shock relies on Double Insulation or Reinforced Insulation) 8. "ON" (power) 9. "OFF" (power) 10. Stand-by (power) 11. "ON"/"OFF" (power; push-push) 12. Caution, risk of electric shock











---

### About the light of door station

- The light is intended to illuminate the subjects in dark environments and not in any other applications.

## 1.5 Symbols, expressions, and styles

The following symbols, expressions, and styles are used in this document.

Item	How it is expressed	Example
Text displayed on the product's display	Text is displayed in a special font, usually enclosed in quotation marks	"Initial settings"
Icons displayed on the product's display	Black-and-white illustration of icon is used	
Buttons with printing on them or near them	Button printing is displayed, usually wrapped in thick brackets	【TALK】 【  】
Soft keys	Black-and-white illustration of the corresponding soft key icon is used	
Procedures	Usually written in an abbreviated style. The verb may be omitted. Unless otherwise stated, all procedures are for the main monitor.	<p><b>Main monitor example</b></p> <p> → "Display" →  → "Brightness"</p> <ul style="list-style-type: none"> <li> <b>Meaning:</b>            Press the soft key under the displayed  soft key icon, press the soft keys under the displayed  and  soft key icons to select "Display", press the soft key under the displayed  soft key icon, and then press  to select "Brightness".         </li> </ul>

## 1.6 Trademarks and registered trademarks

- All other trademarks identified herein are the property of their respective owners.

## 2. Important information

---

### 2.1 For your safety

To prevent severe injury and loss of life/property, read this section carefully before using the product to ensure proper and safe operation of your product.



#### Preventing fire and electric shock

- Use only the power source marked on the product. If you are not sure of the type of power supplied to your home, consult your dealer or local power company.
- Do not attempt to disassemble or modify this product. Contact an authorised service centre for repairs.
- Never touch the power plug with wet hands.
- Do not touch the power plug during an electrical storm.
- Do not use the product (excluding the doorphone) in areas that are exposed to rain, moisture, steam, or oily smoke, or areas that have excessive dust.
- Do not place objects on the power cables. Install the product where no one can step or trip on the power cables.
- Do not allow the power cables to be excessively pulled, bent or placed under heavy objects.
- Do not overload the power outlet or wiring above the specified levels. Overloading by having many connections on one power outlet may cause heat generation, resulting in a fire.
- Never put metal objects inside the product. Never spill any liquid on the product (excluding the doorphone).  
If metal objects enter the product or the product becomes wet, unplug the product from the power outlet and contact an authorised service centre.
- Completely insert the power plug into the power outlets. Failure to do so may cause electric shock and/or excessive heat resulting in a fire. Do not use damaged power plug or power outlets.
- Regularly remove any dust, etc., from the power plug by unplugging it from the power outlet, then wiping it with a dry cloth. Accumulated dust may cause an insulation defect from moisture, etc., resulting in a fire.
- Unplug the product from the power outlet if the product emits smoke, an abnormal smell or makes unusual noise, or if the product has been dropped or physically damaged. These conditions can cause fire or electric shock. Confirm that smoke has stopped emitting and contact an authorised service centre.
- Hold the main body (not the metal parts) of the power plug when unplugging it. Unplugging the power plug while holding its cord may result in fire, electric shock, or injury.



#### Preventing accidents, injuries, and property damage

- Do not use the product in unstable areas or areas prone to strong vibrations. This may cause the product to fall, resulting in damage to the product or injury.
- Do not put your ear(s) near the speaker, as loud sounds emitted from the speaker may cause hearing impairment.

---

### 2.2 Important safety instructions

When using this product, basic safety precautions should always be followed to reduce the risk of fire, electric shock, or personal injury.

1. Do not use this product near water. For example, near a bathtub, wash bowl, kitchen sink, or laundry tub, in a wet basement, or near a swimming pool, etc.
2. Use only the power cable indicated in this document.

#### SAVE THESE INSTRUCTIONS

---

### 2.3 For best performance

#### Environment

- Keep the unit away from electrical noise generating devices, such as fluorescent lamps and motors.
- The unit should not be exposed to direct sunlight.
- The unit should be kept away from heat sources such as radiators, cookers, etc. It should not be placed in rooms where the temperature is less than 0 °C or greater than 40 °C. Damp basements should also be avoided.
- Do not install the product in locations that are suspect to sudden changes in temperature. Failure to do so may cause condensation to form on the product causing malfunction.
- In areas surrounded by a high electrical field, disturbances may occur in the unit's image or sound.

## 2.4 Other important information

- The power plug is used as the main disconnect device. Ensure that the power outlet is installed near the product and is easily accessible.

### Privacy and rights of portrait

When installing or using the doorphone, please take into consideration the rights of others with regard to privacy and rights of portrait.

- It is generally said that "privacy" means the ability of an individual or group to stop information about themselves from becoming known to people other than those whom they choose to give the information. "Rights of portrait" means the right to be safe from having your own image taken and used indiscriminately without consent.
- Please observe the legal regulations (data protection, video surveillance) in your country during use.

### Personal information

The main monitor's internal memory records personal information (image recordings of visitors, etc.). Panasonic assumes no liability for any unforeseen damages arising from the exposure of the recorded information.

- **Disclaimer**  
Recorded data may be altered or deleted as a result of incorrect operations, exposure to static electricity, accidents, malfunction, repairs or other operations. Panasonic assumes no liability for any direct or indirect damages resulting from the loss or alteration of recorded images.

### Requesting repairs for the product

- Before submitting the main monitor for repair, initialize it. This will delete all information saved in the main monitor.\*1
- Even if the product is sent for repairs without being initialized, the memory (including recorded data and settings) for the main monitor may be cleared and set to factory default after repair.
- If operations cannot be performed due to the main monitor malfunction, consult with the place of purchase for appropriate action.

### Note for product disposal, transfer, or return

- This product can store your private/confidential information.  
To protect your privacy/confidentiality, we recommend that you erase the information (recorded images) from the memory before you dispose of, transfer or return the product.  
All the recorded images can be erased at once by initializing the main monitor.\*1

\*1 Main monitor: perform "Factory Setting" in "Initialize settings" (page 19).

### Information on Disposal in other Countries outside the European Union



Above symbol (①) is only valid in the European Union. If you wish to discard this product, please contact your local authorities or dealer and ask for the correct method of disposal.

### Others

- When power fails, this product cannot be used.
- For the recorded image:  
The recorded image may be lost when:
  - Mishandled
  - Electric shock occurs.
  - The power is turned off during use.
- Panasonic may not be liable for damages due to external factors such as power failures.
- If you stop using the main monitor and the doorphone, remove the main monitor and the doorphone from the walls to prevent them from falling off. (Consult your dealer for information about removing the product.)

## 2.5 Environmental Information (India only)

Information on hazardous constituents as specified in sub-rule 1 of rule 16 (1) in electrical and electronic equipment.

Declaration of Conformity with the requirements of the E-Waste (Management) Amendment Rules 2018 with the rule 16 (1) limits with respect to Lead, Mercury, Cadmium, Hexavalent chromium, Polybrominated biphenyls, Polybrominated diphenyl ethers.

The content of hazardous substance with the exemption of the applications listed in SCHEDULE II of the E-Waste (Management) Amendment Rules 2018:

1. Lead (Pb) – not over 0.1% by weight;
2. Cadmium (Cd) – not over 0.01% by weight;
3. Mercury (Hg) – not over 0.1% by weight;
4. Hexavalent chromium (Cr6+) – not over 0.1% by weight;
5. Polybrominated biphenyls (PBBs) – not over 0.1% by weight;
6. Polybrominated diphenyl ethers (PBDEs) – not over 0.1% by weight.

## 2. Important information

### Information of Disposal



For the purpose of recycling to facilitate effective utilization of resources, please return this product to a nearby authorized collection center, registered dismantler or recycler, or Panasonic service center when disposing of this product.

Customer care number (Toll free) : 1800 103 1333, 1800 108 1333

Please see the Panasonic website for further information on collection centers, etc. or call the customer care toll-free number

<http://www.panasonic.com/in/corporate/sustainability/panasonic-india-i-recycle-program.html>

6	Wherever possible or as instructed, separate the packaging material according to responsible waste disposal options and sorting for recycling.	Do not give e-waste to informal and unorganized sectors like Local Scrap Dealers / Rag Pickers.
---	--	---

Do's & Don'ts: E-waste (Management) Amendment Rules 2018		
No.	Do's	Don'ts
1	All electrical and electronic products are required to be handed over only to the Authorized recycler.	The product should not be opened by the user himself / herself, but only by authorized service personnel.
2	The product should be handed over only to authorized recycler for disposal.	The product is not meant for re-sale to any unauthorized agencies / scrap dealers / kabariwalas.
3	Keep the product in an isolated area, after it becomes non-functional / unrepairable so as to prevent its accidental breakage.	The product is not meant for mixing into household waste stream.
4	Refer to Operating Instructions for handling of end of life products.	Do not keep any replaced spare part(s) from the product in an exposed area.
5	Always dispose of products that have reached end of life at Panasonic India Authorized Service Centre.	Do not donate old electronic items to anybody. Do not dispose of your product in garbage bins along with municipal waste that ultimately reaches landfill.



## 3.1 Controls

### 3.1.1 Doorphone

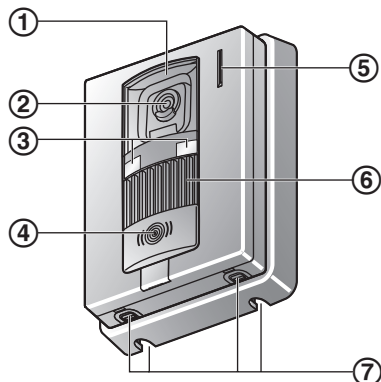

① **Lens cover**

② **Camera lens**

③ **LED lights**

Used to illuminate the visitor's face or the area in front of the doorphone so that the visitor's face can be seen in the dark.

④ **Call button and indicator (red)**

Lights in red when the power is on.

⑤ **Microphone**

⑥ **Speaker**

⑦ **Water drain holes**

These holes allow rain water to drain. Do not cover them.

#### Doorphone image quality

The quality of doorphone images may change depending on the installation environment, settings, lighting conditions, the time of day, etc. See page 21 for more information.

### 3.1.2 Main monitor

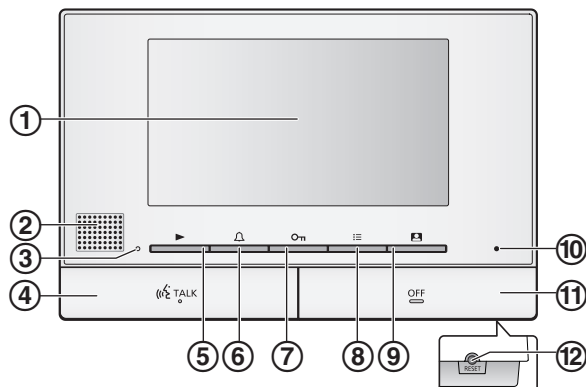

① **Display** (page 11)

② **Speaker**

③ **Play lamp (blue)**

Lights when there is an unplayed image. The indicator turns off when the unplayed image is displayed.

④ **TALK button** (【TALK】)

⑤ **Play button** (【▶】)

Press to display the image playing screen when the main monitor is idle.

It can also be used as a soft key (page 10).

⑥ **Ring volume button** (【🔔】)

Press to display the setting screen when the main monitor is idle.

It can also be used as a soft key (page 10).

⑦ **Unlock button** (【ON】)

⑧ **Menu button** (【☰】)

Press to display the setting screen when the main monitor is idle.

It can also be used as a soft key (page 10).

⑨ **Monitor button** (【📺】)

Press to monitor the outside when the main monitor is idle.

It can also be used as a soft key (page 10).

⑩ **Microphone**

⑪ **OFF button** (【OFF】)

⑫ **RESET button**

If the main monitor cannot be correctly operated, press the **RESET** button with a pointed object to reset the main monitor. (Recorded images and configured settings are not affected.)

### 3. Preparation

---

#### Soft keys

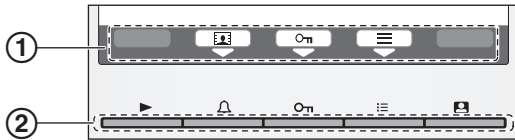

#### ① Soft key icons

Indicate the item that will be selected when you press the soft key directly under each icon. The icons that are displayed vary depending on current screen and operation.

#### ② Soft keys

Select the items displayed on the screen directly above each soft key.

---

#### Ring volume button

1. The volume adjustment screen can be displayed by pressing [] when the main monitor is idle.
  2. To adjust the volume, press or repeatedly to select the desired setting.\*1
- \*1 To mute the sound, press and hold until "" is displayed. To active the sound again, press .

#### Note:

- The ring volume button cannot adjust the ring volume while talking, monitoring, or receiving an incoming call.
- You can also change the ring volume by using the function settings list (see page 18).

## 3.2 Using the display





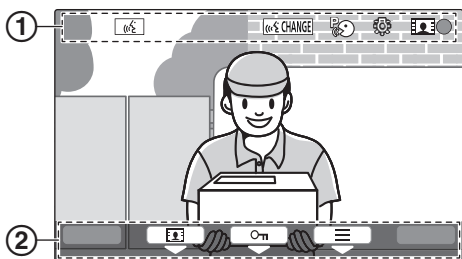

### 3.2.1 Main monitor - display information

#### Image viewing screen











- ① Status icons (page 11)
- ② Soft key icons (page 10)

#### Status icons (main monitor)





-  Indicates that the main monitor is on a call.
-  Indicates that the main monitor is monitoring.
-  Indicates that images are being recorded (page 14).
-  Indicates that the doorphone's LED lights are on (page 17).
-  Indicates that "Press-to-talk" mode is on (page 13).
-  Indicates that voice changer is on (page 17).

## 3.3 Setting the language, date and time

When you use the main monitor for the first time, you will be prompted to set the display language, date, and time settings.

- The play lamp lights if these settings are not configured.
- 1 Press the  button to turn on the display.
  - 2 Press the soft keys under the  and  soft key icons to select the desired language.
  - 3 Press .
  - 4 Press  again.
  - 5 Set the date and time.
    - Press  to select an item (i.e., year, month, day, etc.).
    - Press  or  to change the setting.
  - 6 When finished, press .
    - A beep sounds and the display turns off.

#### Changing the language, date and time

You change the language, date, and time settings later if desired. Press the  button, use the , , and  soft keys to navigate to "Initial settings".

#### Note:

- The date and time settings may be deleted when there is a power outage. In this case, reconfigure the settings.
- The time may become out of sync over time (about 60 seconds per month).

### 3. Preparation

## 3.4 Wide/zoom settings and zoom position settings

These functions are not available for the supplied doorphone (VL-V522L). You can use these functions with optional doorphones (page 3).

You can configure how doorphone images are initially displayed on the main monitor. Images can be displayed in wide mode or in zoom mode. You can choose different settings for when visitors call you, and for when you are monitoring.

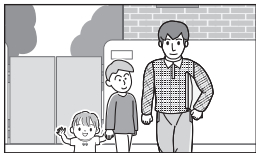
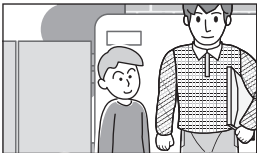
Wide mode (default setting)	Zoom mode
	
Images are not zoomed. The full camera image is displayed.	Images are zoomed. Images are displayed 2 times larger than wide display.

#### Note:

- The zoom feature uses a digital zoom. As a result, the image quality of zoomed images is lower than wide display images.
- You can switch between wide and zoom modes and adjust the zoom position while monitoring or on a call. See page 17.

#### Selecting wide or zoom

1. Press **[☰]** → select “Initial settings” → **[OK]**.
2. Select “Wide/Zoom settings” → **[OK]**.
3. Select the desired setting → **[OK]**.
  - “When visitors come”: Your settings will be used when you answer calls from visitors.
  - “When monitoring”: Your settings will be used when you are monitoring.
4. Select the desired display mode → **[OK]**.
  - A beep sounds and the settings are changed.
5. When finished, press **[OFF]**.

#### Note:

- If you select “zoom”, adjust the zoom position so that people or objects that you want to view are displayed centrally in the screen.
- When images are recorded in zoom mode, only the zoomed area is recorded.

#### Selecting the zoom position (pan/tilt position)

You can select which area of the image is displayed when displaying zoomed images.

1. Press **[☰]** → select “Initial settings” → **[OK]**.
2. Select “Zoom position settings” → **[OK]**.
  - A zoomed image from the doorphone is displayed.
3. Select the desired zoom position → **[OK]**.
  - A beep sounds, the settings are changed, and the display turns off.

#### Note:

- If you do not perform any operations for 90 seconds while changing this setting, the setting is cancelled and the screen turns off.

## 4.1 Answering doorphone calls

When you receive a call from a doorphone, the main monitor rings and displays an image from the doorphone.

### To answer the call

Press **[TALK]**.

- Speak within about 50 cm of the microphone.
- Speak alternatively with the visitor. If you and the visitor speak at the same time, you will not hear each other.
- You can talk for up to about 90 seconds.

### To end the call

Press **[OFF]**.

#### Note:

- The display will turn off if you do not answer a call within about 30 seconds.
- The displayed images are automatically recorded to the main monitor (page 14).

### Features available during incoming calls

- Monitoring feature (page 13)

### Features available while talking

- Adjusting wide/zoom and pan/tilt settings (page 17)\*<sup>1</sup>
- Turn on or off the operation guide (page 17)
- Adjusting sound and display settings (page 17)
- Using "press-to-talk" (page 13)

\*<sup>1</sup> These functions are not available for the supplied doorphone (VL-V522L). You can use these functions with optional doorphones (page 3).

### Press-to-talk mode

If it is difficult for you and the visitor to hear each other due to noise, the "press-to-talk" mode can make conversations easier to hear.

1. While talking, activate press-to-talk mode by pressing and holding **[TALK]** for about 2 seconds.
  - A beep sounds and  is displayed.

#### 2. To speak to the visitor

Speak while pressing and holding **[TALK]**.

-  is displayed in yellow.

#### To listen to the visitor

Release **[TALK]**.

-  is displayed in white.

#### Note:

- Press-to-talk mode is cancelled when the call ends.

## 4.2 Monitoring the outside with the doorphone

You can monitor the sounds and images from the doorphone using the main monitor.

1 Press **[MONITOR]**.

- The images from the doorphone are displayed.

2 Monitor the sound and image.

- You can talk to the monitored party by pressing **[TALK]**.

3 When finished, press **[OFF]**.

#### Note:

- The sound from your end will not be heard at the doorphone.
- You can monitor for up to about 3 minutes.

### Features available while monitoring

- Recording doorphone images (page 14)
- Adjusting wide/zoom and pan/tilt settings (page 17)\*<sup>1</sup>
- Turn on or off the operation guide (page 17)
- Adjusting sound and display settings (page 17)

\*<sup>1</sup> These functions are not available for the supplied doorphone (VL-V522L). You can use these functions with optional doorphones (page 3).

## 5. Recording and playing

### 5.1 Recording doorphone images

The main monitor can record doorphone images (still images). They can save images from up to 50 doorphone calls or monitoring sessions. Each time new images are recorded, they are saved in an image set of up to 4 images.

#### 5.1.1 Recording automatically (recording a received call)

When a visitor calls you, the main monitor records 4 images automatically (whether you answer the call or not). Recording starts about 2 seconds after you receive the call.

#### When you do not answer a call

The recorded images are saved as unplayed images, and the play lamp lights.

#### When the memory is full (auto image updating)

When the memory is full, new images overwrite the oldest images automatically. This occurs even if the oldest images are unplayed images.

#### 5.1.2 Recording manually (recording while monitoring)

The main monitor can manually record images while monitoring.

While monitoring, press . Up to 4 images will be recorded.

–  is displayed on the screen when recording.

### 5.2 Playing recorded images

When there are new (i.e., unplayed) images recorded, the play lamp (page 9) lights.

- 1 Press .
  - “Recorded image list” screen is displayed.
- 2 Select “Unplayed images” (for new images) or “Played images” (for images that have been played) → .
  - The most recent image set of the selected type is displayed.
- 3 Browse the image sets and images.
  - The following operations are available when browsing images.
  - See page 14 for a list of all available operations.

 Plays back all images in an image set continuously

 Browses image sets, from older ones to newer ones

 Browses image sets, from newer ones to older ones

 Displays the options menu

 Returns to the previous screen

- 4 When finished, press [OFF].

#### Note:

- The play lamp turns off when the unplayed image is displayed.

#### 5.2.1 Image playing screen

##### Image playing screen





- ① Image position within a image set
- ② Image set number
- ③ Recording date and time
- ④ Indicates that the image has not been played.

#### Status icons

 Indicates that the image is protected (i.e., cannot be deleted)

#### Available soft keys

 Plays back all images in an image set continuously

 Browses image sets, from older ones to newer ones

 Browses image sets, from newer ones to older ones

 Displays the options menu

 Returns to the previous screen

 Pauses continuous playback

 Plays the previous image in an image set when continuous play is paused



 Plays the next image in an image set when continuous play is paused

---

### 5.2.2 Options available when playing images



While playing images, you can press  to display the options menu and change the following settings.

#### To turn off the operation guide



 → select “Guide off” → .

- While the guide is turned off, the soft keys do not operate their respective features. Press any soft key to display the guide again briefly. During this time, the soft keys can be operated as normal.

#### To turn on the operation guide



Press any soft key to display the guide →  → select “Guide on” → .

#### To turn protection on and off

 → select “Protect” (to turn protection on) or “Remove protection” (to turn protection off) → .

- When “Protect” is selected, the image cannot be deleted.
- A maximum of 20 image sets can be protected.

#### To delete the current image

 → select “Delete” →  → .

- You can use “Delete all images” to delete all images in one operation. See page 19.

#### To adjust the screen brightness

 → select “Brightness” → adjust the brightness.

## 6. Using electric locks and doorbells

---

### 6.1 Using electric locks

When a commercially available electric lock is connected to 1 main monitor, you can unlock a door using the main monitor. You can also select the length of time control signals are sent for to unlock the door. (How long the door remains unlocked depends on each electric lock's specification.)

- A maximum of 1 electric lock can be connected to the main monitor.
- For detailed information about connections, see the operating instructions included with the electric lock and the Installation Guide of this product.

#### 6.1.1 Configuring electric locks

- 1 Press **[☰]**.
- 2 Select "Connected devices" → **[OK]**.
- 3 Select "Electric lock" → **[OK]**.
- 4 Select "Doorphone" → **[OK]**.
- 5 Select the device that the electric lock is connected to → **[OK]**.
- 6 Select the unlocking time → **[OK]**.
- 7 When finished, press **[OFF]**.

#### Electric lock settings

Options listed below are available.

"Unlocking buzzer sound":

Determines whether the doorphone sounds a buzzer when the electric lock is unlocked. See page 19.

"View extension after unlocking":

Determines whether to extend the displaying time of the doorphone image when the electric lock is unlocked. See page 19.

#### 6.1.2 Unlocking electric locks

- 1 Press **[On]** during an incoming call, or while talking or monitoring.

### 6.2 Doorbells

A doorbell may be connected to your main monitor. In this case, the main monitor will ring when someone presses the doorbell button.

When a doorbell is connected to your main monitor, configure the main monitor as follows.

Press **[☰]** → select "Connected devices" → **[OK]** → select "Door bell" → **[OK]** → select "Device connected" → **[OK]**. When a beep sounds, press **[OFF]**.

#### Note:

- Connect a doorbell to the IN1 and IN2 terminals. (The doorbell will not operate if connected to other terminals.)



## 7.1 Zooming in and out (wide/ zoom, pan/tilt)

These functions are not available for the supplied doorphone (VL-V522L). You can use these functions with optional doorphones (page 3).

When on a call or monitoring, you can display images in wide mode or in zoom mode. During zoom mode, you can change the zoom position (also called "pan/tilt").





### To switch from wide mode to zoom mode

Press .

### To switch from zoom mode to wide mode

Press .

### To change the zoom position in zoom mode



 → "Pan/tilt" →  → press  or 

#### Note:



- See page 12 for examples of wide mode and zoom mode.
- The zoom feature uses a digital zoom. As a result, the image quality of zoomed images is lower than wide display images.
- When images are recorded in zoom mode, only the zoomed area is recorded.
- If you adjust these settings, the settings will be cancelled the next time you display an image. To change how doorphone images are initially displayed on the main monitor, see page 12.

During this time, the soft keys can be operated as normal.



### To turn on the operation guide

Press a soft key other than  to display the guide →  → "Guide on" → .



### To adjust the screen brightness

 → "Display" →  → "Brightness" → select the desired setting.

### To adjust backlight compensation

 → "Display" →  → "Backlight compensation" → select the desired setting.

### To turn the LED lights on or off

 → "Display" →  → "Illumination" → select the desired setting.



-  is displayed when the LED lights are on.

- \*1 These settings cannot be changed during an incoming call.
- \*2 The main monitor can use the voice changer by pressing  during incoming calls.

## 7.2 Sound and display settings for calls and monitoring

While monitoring or on a call, you can press  to display the options menu and change sound and display settings.



### To adjust the incoming call volume\*1

 → "Sound" →  → "Receiver volume" → adjust the volume.

### To adjust the volume heard at the doorphone\*1

 → "Sound" →  → "Owner's voice volume" → select the desired setting.

### To use the voice changer\*2 (makes the voice heard at the doorphone sound deeper)

 → "Sound" →  → "Voice changer" → select the desired setting.

### To turn off the operation guide

 → "Guide off" → .

- While the guide is turned off, the soft keys do not operate their respective features. Press a soft key other than  to display the guide again briefly.

## 7. Additional functions

### 7.3 Ringtone settings

You can change the ringtone type and volume that is heard during an incoming call.

- For information about how to configure settings, see page 18.

### 7.4 Main monitor - function settings list

You can change the settings to match how the main monitor is used.

- 1 Press [☰].
- 2 Select the desired item → [OK].
  - Repeat this step as necessary to navigate to the desired setting.
- 3 Select the desired setting → [OK].
- 4 Press [OFF].

#### Note:

- If you do not perform any operations for 90 seconds while changing these settings, or if an incoming call is received, the setting is cancelled and the screen turns off.
- In the following table, default settings are indicated by < >.
- While changing settings, “●” is displayed to the left of the currently selected item.

#### Item name: “Initial settings”

Sub-menu		Settings	
1	2		
Time and date settings* <sup>1</sup>	–	2021-1-1 0:00	
Zoom position settings* <sup>2</sup>	–	–	For details see page 17.
Wide/Zoom settings* <sup>2</sup>	When visitors come/When monitoring	Zoom, <Wide>	
Power supply frequency	–	<50 Hz>, 60 Hz – To prevent mottled or uneven colour from being displayed, choose the appropriate power supply frequency for your area.	
Adjust image quality	Colour (red) Colour (blue)	– Adjust the colouring of images from the doorphone or lobby station. 5 levels can be selected for each colour (default setting: level 3).	
Select language* <sup>1</sup>	–	<English>, Tiếng Việt, العربية	

\*<sup>1</sup> When using the product for the first time, follow the on-screen instructions to configure this setting (page 11).

\*<sup>2</sup> These functions are not available for the supplied doorphone (VL-V522L). You can use these functions with optional doorphones (page 3).

#### Item name: “Ringtone”

Sub-menu		Settings	
1	2		
Ring volume	–	Extra loud, <Loud>, Normal, Quiet, Mute	
Ringtone	Doorphone	<Sound 1>, Sound 2, Sound 3	<Normal>, Repeat
	Door bell	Sound 1, <Sound 2>, Sound 3	<Normal>, Repeat

## Item name: "Connected devices"

Sub-menu			Settings	
1	2	3		
Door bell	–	–	Device connected, <Device not connected>	
Electric lock	Doorphone	Connect to the electric lock 1/ Connect to the doorphone/<No connection>	<Unlock for 1 second> - Unlock for 7 seconds	
	Unlocking buzzer sound	–	<On>, Off	For details see page 16.
	View extension after unlocking	–	Enable, <Disable>	
Automatic illumination* <sup>1</sup>	When visitors come/When monitoring	–	<Enable>, Disable	

\*1 With this setting, you can select whether or not to automatically turn on the LED lights when the area surrounding the doorphone is dark.

## Item name: "Other"

Sub-menu		Settings
1	2	
Play lamp	–	<Enable>, Disable
Delete all images	Delete all images/Delete Non-protected images	Yes, No
Initialize settings	Default setting* <sup>1</sup> /Factory setting – Select "Factory setting" when disposing, transferring, or returning the product.	Yes, No
Demo mode	–	On, <Off>

\*1 The following settings are not initialized.  
– "Power supply frequency", "Select language", and "Electric lock" settings.

## Item name: "Operating instructions"

Sub-menu	Settings
1	
Operating instructions	Displays the Web site for downloading the Operating Instructions.

## 8. General information

### 8.1 Cleaning

Wipe the product with a soft, dry cloth.

For excessive dirt, wipe the product with a cloth slightly dampened with fresh water.

#### Important:

- Do not use any cleaning products that contain alcohol, polish powder, powder soap, benzene, thinner, wax, petroleum, or boiling water. Also do not spray the product with insecticide, glass cleaner, hair spray, or wall paint. This may cause a change in colour or quality of the product.

### 8.2 Specifications

#### Main monitor (VL-MV70)

<b>Power source</b>	220-240 V AC, 50/60 Hz
<b>Power consumption</b>	Standby: 2.0 W Operating: 10.5 W
<b>Dimensions (mm) (height × width × depth)</b>	Approx. 158×243×29.5 (excluding protruding sections)
<b>Mass (weight)</b>	<ul style="list-style-type: none"><li>• VL-MV70BX: approx. 760 g</li><li>• VL-MV70CX: approx. 810 g</li><li>• VL-MV70SX: approx. 780 g</li></ul>
<b>Operating environment</b>	Ambient temperature: approx. 0 °C to +40 °C Relative humidity (non-condensing): up to 90 %
<b>Display</b>	Approx. 17.8 cm (7.0 inches wide colour display)
<b>Talking method</b>	Hands-free
<b>Installation method</b>	Wall mount (mounting bracket supplied)

#### Doorphone (VL-V522L)

<b>Power source</b>	Power supplied by the main monitor
<b>Dimensions (mm) (height × width × depth)</b>	Approx. 131×99×36.5 (excluding protruding sections)
<b>Mass (weight)</b>	Approx. 200 g
<b>Operating environment</b>	Ambient temperature: approx. -15 °C to +55 °C Relative humidity (non-condensing): up to 90 %
<b>Viewing angle</b>	Horizontally: approx. 87° Vertically: approx. 66°
<b>Installation method</b>	Wall mount (mounting base supplied)

<b>Minimum illuminance required</b>	1 lx (within approx. 50 cm from the camera lens)
<b>Lighting method</b>	LED lights

## 9.1 Troubleshooting

### Monitor display (doorphone images)

Problem	Cause & Solution	Page
Images appear distorted.	<ul style="list-style-type: none"> <li>Images may appear distorted because of the characteristics of the camera lens. This is not a malfunction.</li> </ul>	–
The image of the subject is displayed in black and white (or bluish-purple).	<ul style="list-style-type: none"> <li>At night or when there is poor light in the area around the doorphone, the image of the subject may be displayed in black and white (or bluish-purple). <ul style="list-style-type: none"> <li><b>When using a doorphone equipped with LED lights</b> The doorphone's LED lights may be turned off. Turn on the LED lights when it is dark.</li> <li><b>When using a doorphone not equipped with LED lights</b> We recommend installing extra lights in the area around the doorphone.</li> </ul> </li> </ul>	17 19
The background appears greenish.	<ul style="list-style-type: none"> <li>At night or when there is poor light in the area around the doorphone, lights or white objects near the doorphone may appear greenish. This is not a malfunction.</li> </ul>	–
Images at night are dark and faces cannot be identified.	<ul style="list-style-type: none"> <li><b>“Automatic illumination”</b> is set to <b>“Disable”</b>. → Change the setting to <b>“Enable”</b>.</li> <li>Even when the doorphone's LED lights are lit, because the light from the LED lights cannot illuminate the edges of the visible area (the areas directly next to the doorphone), faces of people may not be identifiable even when they are close to the doorphone. → We recommend installing extra lights in the area around the doorphone.</li> </ul>	19 –
The images of people's faces are dark.	<ul style="list-style-type: none"> <li>Images of people's faces appear dark when there is strong sunlight or a backlight in the area around the doorphone. → Use the backlight compensation function.</li> </ul>	17
Images are dirty or unclear. <ul style="list-style-type: none"> <li>Images are not in focus.</li> </ul>	<ul style="list-style-type: none"> <li>There is dirt on the surface of the doorphone's lens. → Wipe the lens with a soft, dry cloth.</li> <li>There is water condensation on the surface of the doorphone's lens. → Wait for the condensation to evaporate.</li> </ul>	20 –
Images are white or black.	<ul style="list-style-type: none"> <li>The brightness of the display is not correctly adjusted. → Adjust the brightness when images are displayed.</li> </ul>	15
Images are white, or white lines or circles are shown on the display.	<ul style="list-style-type: none"> <li>Strong light such as sunlight is shining into the lens of the doorphone causing images to be difficult to see on the display. (This is not a malfunction.) → Locating the doorphone away from direct sunlight or changing the angle that the doorphone is installed may help reduce this problem.</li> </ul>	–
There is a small black dot in the background.	<ul style="list-style-type: none"> <li>If the sun can be seen, its centre appears as a black dot. This is not a malfunction.</li> </ul>	–
Images are flickering.	<ul style="list-style-type: none"> <li>AC (alternating current) lights such as fluorescent lights are used near the doorphone. → AC (alternating current) lights such as fluorescent lights may cause flickering in dark environments. (This is not a malfunction.)</li> </ul>	–
Images of the area you want to view in the zoom screen are not displayed correctly.*1	<ul style="list-style-type: none"> <li>Change the zoom position setting to a suitable position. → Configure the <b>“Zoom position settings”</b> settings.</li> </ul>	12



\*1 The wide/zoom setting is not available for the supplied doorphone (VL-V522L).

## 9. Troubleshooting

### Ringtone

Problem	Cause & Solution	Page
The ringtone for the doorphone does not sound.	<ul style="list-style-type: none"> <li>The ringtone volume is muted. → Activate the sound for the ringtone.</li> </ul>	18

### Calls

Problem	Cause & Solution	Page
Sound cuts in/out or fades.	<ul style="list-style-type: none"> <li>The area surrounding the main monitor or doorphone are noisy, causing the sound to cut out or fade. → Try using the "Press-to-talk" mode.</li> </ul>	13
Calls cannot be heard because of noise or feedback.	<ul style="list-style-type: none"> <li>Noise or feedback may occur when you are too close to the other party. → Move away from the other party.</li> </ul>	-
Your voice cannot be heard by the visitor but the visitor's voice can be heard.	<ul style="list-style-type: none"> <li>You are using the "Press-to-talk" mode. (  is displayed on the main monitor.) → When using the "Press-to-talk" mode, the visitor can hear your voice only while you are pressing [  TALK ].</li> </ul>	13

### Others

Problem	Cause & Solution	Page
<ul style="list-style-type: none"> <li>"Demo mode" is displayed on the screen.</li> <li>The ringtone regularly sounds.</li> <li>You cannot talk or make calls.</li> </ul>	<ul style="list-style-type: none"> <li>The "Demo mode" feature is enabled. → Set "Demo mode" to "Off".</li> </ul>	19
The product does not work with correct operations. The product does not work properly.	Perform the following operations. → Press the [RESET] button on the bottom side of the main monitor with a pointed object. (Recorded images and configured settings are not affected.)	9
The main monitor does not work properly. <ul style="list-style-type: none"> <li>Nothing is displayed on the monitor.</li> <li>The ringtone does not sound.</li> <li>Voices cannot be heard.</li> </ul>	<ul style="list-style-type: none"> <li>Check the power connection.</li> <li>If the power is connected, there may be a problem with the electrical wiring. → Contact an authorised service centre.</li> </ul>	-



Panasonic Corporation

1006, Oaza Kadoma, Kadoma-shi, Osaka 571-8501, Japan

<http://www.panasonic.com>

© Panasonic Corporation 2020

**PNQP1648YA** C1020MM1021