

Installation Guide

Model Name	Model No.
Video Intercom System	VL-SV74 VL-SV75
Main Monitor Station	VL-MV74 VL-MV75
Door Station	VL-V524

- This guide is for use with the above 5 models.



Door station

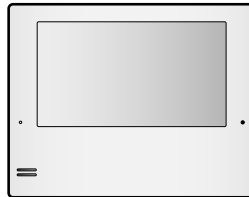

Main monitor station

- The Installation Guide in Indonesian and Thai can be accessed from the following site:
<https://panasonic.net/cns/pcc/support/intercom/sv74>
- Door station is described as "doorphone" and Main monitor station is described as "main monitor" in this guide.
- In this guide, the suffix of each model number (e.g., the "BX" in "VL-SV74BX") is omitted unless necessary.

Note to the installer

- Before attempting to connect or operate this product, please read the label on the rear of the doorphone and the main monitor/extension monitor.
- Please read this guide carefully, and install the product safely and correctly by following the instructions. Carefully read the information found in the section titled "For your safety" in particular.
- Only use attachments/accessories specified by the manufacturer.
- The installation shall be carried out in accordance with all applicable installation rules.
- To the maximum extent permitted by law, Panasonic assumes no responsibility for injuries or property damage resulting from failures arising out of improper installation or operation inconsistent with this document.
- After installation, make sure to leave this guide with the customer.

For your safety

To prevent severe injury or loss of life or property, and to ensure proper and safe operation of your product, read this section carefully before using the product.



WARNING

Preventing fire, electric shock and short circuits

- **Leave installation work to the dealer. Installation work requires technique and experiences. Failure to observe this may cause fire, electric shock, injury, or damage to the product. Consult the dealer.**
- **Electrical connection work should be performed by certified personnel only. Certification is required for performing electrical connection work. Consult your dealer.**
- Use only the specified power supply unit and AC cable.
- Do not attempt to disassemble or modify this product. Contact an authorised service centre for repairs.
- Never install wiring during a lightning storm.
- Do not connect non-specified devices.
- Do not connect a power cable to a terminal that is not specified in this guide.
- When opening holes in walls for installation or wiring, or when securing the power cable, make sure you do not damage existing wiring and ductwork.

- Do not make any wiring connections when the power supply is turned on.
- Do not use the supplied power supply unit for outdoor installations (it is for indoor use only).
- Do not install the main monitor/ extension monitor in the following places:
 - Places where the main monitor/ extension monitor may be splashed with water or chemicals.
 - Places where there is a high concentration of dust, or high humidity.
- Do not place objects on the power cables.
Install the product where no one can step or trip on the power cables.
- Do not allow the power cables to be excessively pulled, bent or placed under heavy objects.
- When existing wires are used, it is possible that they contain AC voltage. Contact an authorised service centre.



CAUTION

Preventing electric shock



- If the wiring is underground, do not make any connections underground.
- If the wiring is underground, use a protection tube.
- If the wiring is outdoors, use a protection tube or a surge protector.



Preventing injury



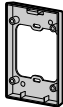

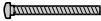
- Install the product securely adhering to the instructions in this guide to prevent it from falling off the wall. Avoid installing onto low-strength walls, such as gypsum board, ALC

(autoclaved lightweight concrete),
concrete block, or veneer (less than
18 mm thick) walls.

Supplied accessories for installation

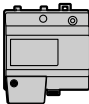
For the doorphone*1		
 Mounting base × 1	 Screw × 2 (3.8 mm × 20 mm)	 Screw × 4 (4 mm × 12 mm)  Screw × 4 (4 mm × 25 mm)*2

For the main monitor/extension monitor	
 Mounting bracket × 1	 Screw × 2 (4 mm × 16 mm)

Power supply unit and related items*3		
 Power supply unit × 1 (VL-PS241)	 AC cable × 1	 Cable binder × 1  Screw × 2 (4 mm × 40 mm)

Important:

- You will need the following additional items to install and configure the doorphone and the main monitor/extension monitor.

[Locally procured]

- Power cables (DC cables)*3, wires (for doorphone and other connections):
 Prepare wires of the appropriate specification. (→ "Wire type and length")

Note:

- The illustrations in the supplied manual(s) may vary slightly from the actual product.

*1 VL-SV74/VL-SV75 models only

*2 Used when using a separately sold flush mount box for installation.

*3 VL-SV75AZ/VL-MV75AZ models only

Precautions for installation

To avoid malfunction or communication disturbances, do not install the doorphone or the main monitor/extension monitor in the following locations:

- Places where vibration or any other kind of impact occurs.
- Places where echoing is frequent.
- Places near a high concentration of dust, hydrogen sulphide, ammonia, sulphur, or noxious fumes.

For the doorphone

- If a strong light is shining on the doorphone, the visitor's face may not be distinguishable. Do not place the doorphone in the following locations:
 - Where most of the background is the sky.
 - Where the background is a white wall, and direct sunlight will reflect off it.
 - Where direct sunlight will shine on the doorphone.
- Do not place the doorphone in locations where echoing occurs, as this will cause the doorphone to beep frequently.
- Dust protection/water protection is IP44.
Only when installation work specified in this guide is properly performed and appropriate water protection treatment is performed.
- Make sure the rear of the doorphone is not subject to water.
- Depending on the installation location, condensation may form on the doorphone's lens cover. This may cause images to become obscured. Condensation will dissipate as the temperature rises.

For the main monitor/extension monitor

- Leave at least 20 cm of space above, below, and to the left and right sides of the main monitor/extension monitor. Do not install on a wall that is deeply recessed.
- Do not install the main monitor/extension monitor inside a wall.
- Be sure to install the main monitor/extension monitor more than 5 m away from the doorphone.
- In areas surrounded by a high electrical field, disturbances may occur in the main monitor's/extension monitor's image or sound.

Important:

- Do not use any cleaning products that contain alcohol, polish powder, powder soap, benzene, thinner, wax, petroleum, or boiling water. Also do not spray the product with insecticide, glass cleaner, hair spray or wall paint. This may cause a change in colour or quality of the product.

Wiring schematic diagram

Set up correctly according to the following wiring schematic diagram and "Wire type and length".

- For information, such as order numbers, about optional devices that can be connected to the "Additional/replacement accessories" section in the Operating Instructions.

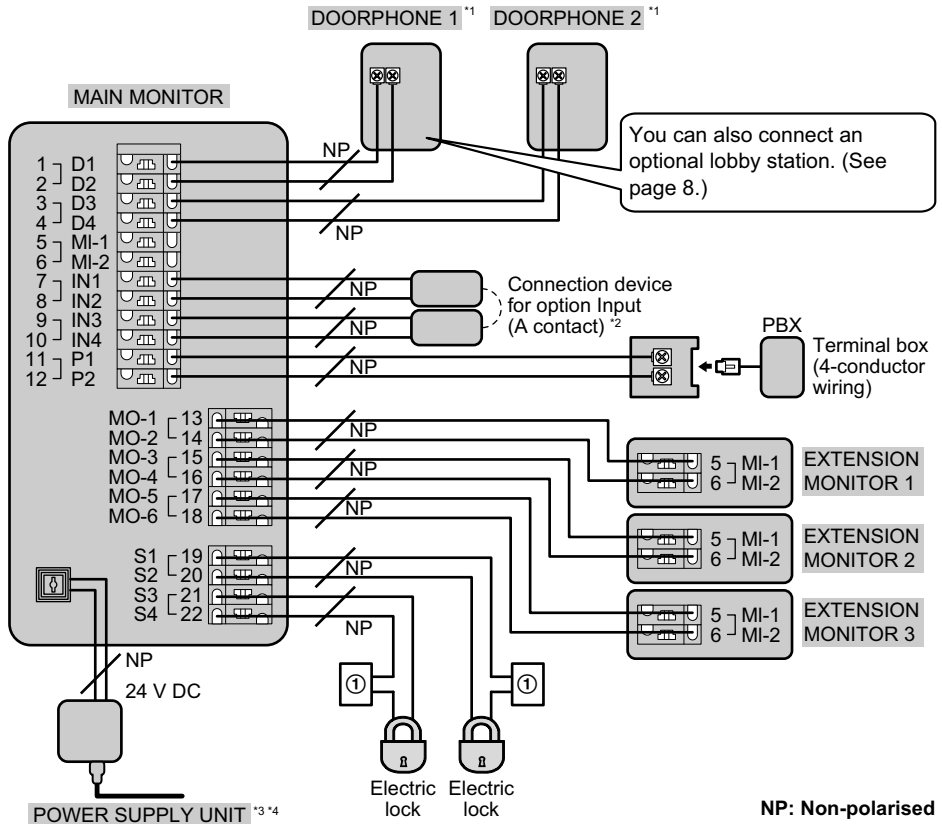

① Power supply

*1 When you use an additional doorphone, the maximum number of the electric locks that can be connected to the doorphone depends on the type of doorphone. Consult your dealer for further information.

For VL-V554 users:

- The electric lock can also be connected to the S1/S2 terminals of the doorphone.

*2 Connection devices for option input (A contact).

- Make sure to connect doorbells to the IN3/IN4 terminals. A doorbell and doorphone 2 cannot be used together.
- When a VL-V901 and VL-V700 series Video Intercom System for Apartment Complexes is used, emergency terminals can be used. Make sure to connect emergency terminals to the IN1/IN2 terminals.

*3 VL-SV75AZ/VL-MV75AZ models only

*4 VL-MV75AZA/VL-MV75BXA models

A power supply unit is not included with the product. Please purchase and connect a separately sold VL-PS240 or VL-PS2410.

Wire type and length

Wiring run	Wire type*1		
	Diameter		Length (Max.)
Doorphone – Main monitor – Extension monitor*2	ø 0.65 mm	22 AWG	100 m
	ø 1.0 mm	18 AWG	130 m
	ø 0.5 mm	CAT 5	50 m
Main monitor – Power supply unit	ø 0.65 mm	22 AWG	10 m
	ø 1.0 mm	18 AWG	20 m
Main monitor – Electric lock*3	ø 0.5 mm - ø 1.2 mm (24 AWG - 17 AWG)		According to the specifications of the connected device.
Main monitor – Connection device for option input (A contact)*3	ø 0.5 mm - ø 1.2 mm (24 AWG - 17 AWG)		According to the specifications of the connected device.
Main monitor – PBX	ø 0.65 mm	CAT 3 or 22 AWG	100 m

*1 Type: Single-pair cable with outer sheath (jacket)

Conductor: Copper solid

- A certified power supply wiring has to be used with this equipment. The relevant national installation and/or equipment regulations shall be considered. A certified power supply wiring not lighter than ordinary polyvinyl chloride flexible wiring according to IEC 60227 shall be used.

*2 When an extension monitor is used, make sure that the total wiring length from the doorphone to the main monitor and then to the extension monitor, is within about 100 m.

*3 When using an electric lock or a connection device for option input (A contact), select a device that meets the following guidelines:

- Electric lock connection terminal (S1/S2, S3/S4):
 - N/O dry closure contact
 - 30 V AC (1 A)/24 V DC (1 A) or lower
- Connection device for option input (A contact) terminal (IN1/IN2/IN3/IN4):
 - Input method: No-voltage contact
 - Open-circuit voltage between terminals: DC 7 V or less
 - Detection definite time: 0.1 second or more
 - Short-circuit between terminals: 5 mA or less
 - Resistance value: make: 500 Ω or less, break: 15 KΩ or more

■ Connecting an optional lobby station

For information about connections, refer to the documentation of the lobby station to be connected.

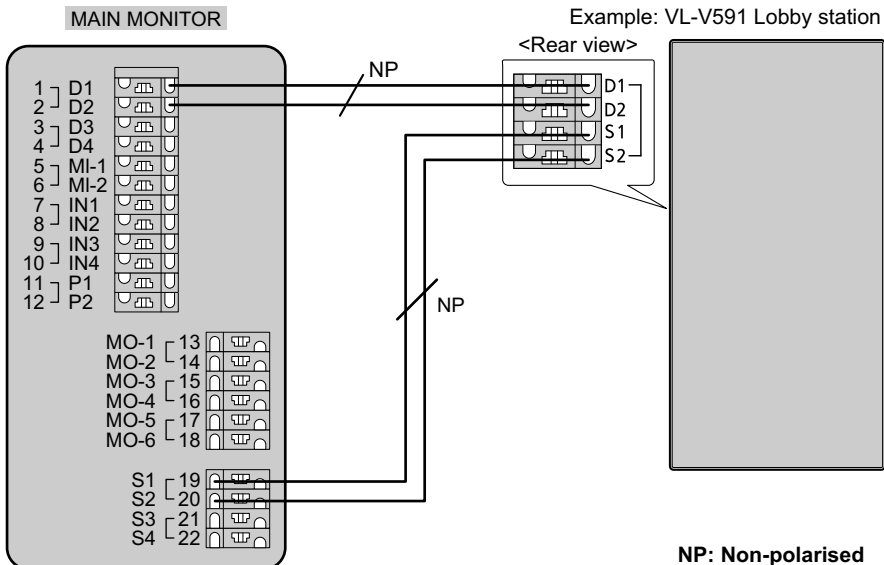

<Be sure to perform the following to ensure proper operation>

● Connecting an optional VL-V591 lobby station

- Connect terminal D1/D2 on the main monitor with terminal D1/D2 on the lobby station.
- Connect terminal S1/S2 on the main monitor with terminal S1/S2 on the lobby station.
- After connecting to the main monitor, change the [Lobby connection] setting to [Device connected] using the main monitor. (→Operating Instructions of the Video Intercom System.)

Note:

- **Connection for VL-V901 and VL-V700 series Video Intercom System for Apartment Complexes**
 - Connect terminal D1/D2 on the main monitor with terminal D1/D2 on the VL-V701 Distribution Box.
- **Connection for VL-VM series/VL-VM701 Video Intercom System - Lobby station/Distributor**
 - Connect either terminal D1/D2 or D3/D4 on the main monitor with the terminal on the Lobby station or VL-VM701 Distributor.

Doorphone installation position

Installation position of the doorphone and camera range

Views when the camera is facing forwards at 0° (default).

- Example: Installation height is 1450 mm (standard position).

(Units: mm)

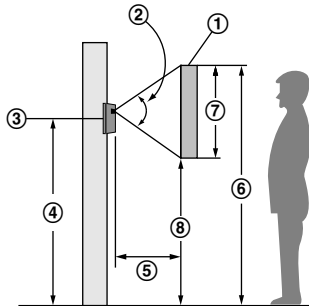

A view when looking from above

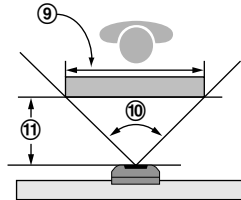

- ① Image range ② Approx. 54° ③ Centre of doorphone ④ Approx. 1450 ⑤ Approx. 500
 ⑥ Approx. 1740 ⑦ Approx. 510 ⑧ Approx. 1230 ⑨ Image range: Approx. 920 ⑩ Approx. 85°
 ⑪ Approx. 500

The camera angle can be adjusted using the camera angle control lever on the rear of the doorphone (step 3, "Installing the doorphone"), so that the image range can be changed.

Side view when the camera is installed lower than the standard position, and facing upwards at 15°.

- Example: Installation height is 1100 mm.
- (Units: mm)

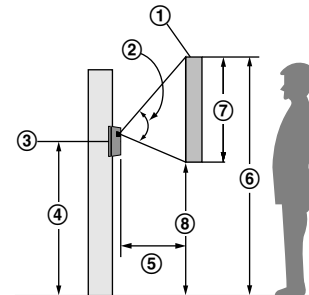

Top view when the camera is facing left or right at 15°*1.

- Example: Camera angle faces left 15°.

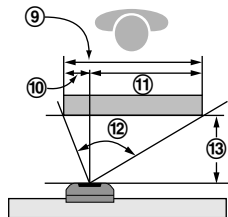

- ① Image range ② Approx. 54° ③ Centre of doorphone ④ Approx. 1100 ⑤ Approx. 500
 ⑥ Approx. 1590 ⑦ Approx. 560 ⑧ Approx. 1030 ⑨ Image range: Approx. 1050 ⑩ Approx. 260
 ⑪ Approx. 790 ⑫ Approx. 85° ⑬ Approx. 500

*1 If the camera points 15° upwards, the left or right angle is less than 5°.

Note:

- The measurements and angles are for reference purposes and may vary depending on the environment.

Installing the doorphone

Important:

- On the bottom surface of the doorphone and the mounting base, there are holes to allow water to drain. Do not cover them up when installing.
- When existing wiring (such as chime wires) is used:
 - It may contain AC voltage that may cause electric shock and/or damage the product.
 - Never use the following types of wiring. Consult a qualified technician/dealer.

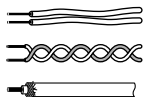

- See "Wire type and length" for information about wiring materials.

- 1 Attach the mounting base (2) (accessory) to the wall securely.
 - Install the mounting base on a vertical flat wall.

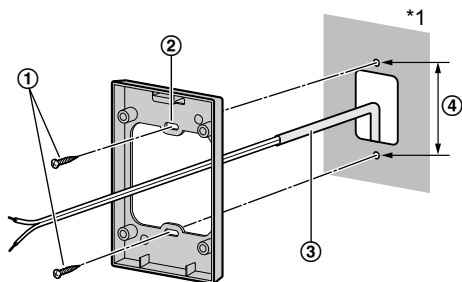

- ① Screws (accessory) × 2
- ③ Wire (locally procured)
- ④ 83.5 mm

*1 To prevent dew condensation, fill a hole for wiring as much as possible.

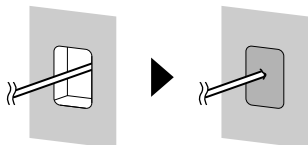

When using flush mount box (option):

Model No. VL-MB524

Install the flush mount box (1) in the wall.

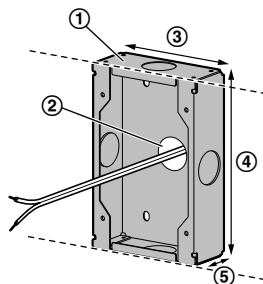

- ② Knockout hole*1
- ③ Approx. 90 mm
- ④ Approx. 138 mm
- ⑤ Approx. 37 mm

*1 Only open the knockout holes as required for the wiring.

- 2 Use a slotted screwdriver (1) to push into the holes on the bottom side of the front panel, and remove the front panel (2) of the doorphone.

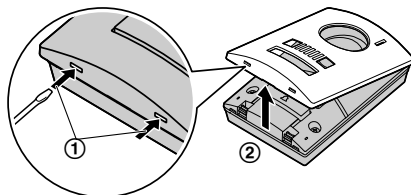

- 3 Adjust the camera angle using the camera angle control lever.

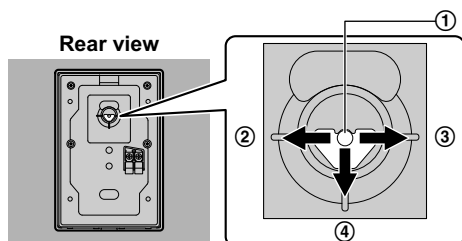

- ① Camera angle control lever
- ② Left (maximum 15°)
- ③ Right (maximum 15°)
- ④ Upwards (maximum 15°)

Examples of camera angle

Facing forwards

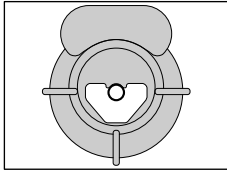

Facing upwards

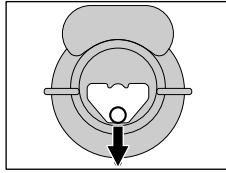

Facing left

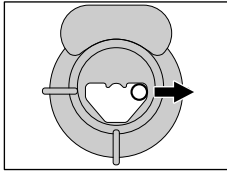

Facing upper left

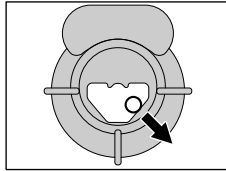

- The angle can also be adjusted to the right or upper right.

Important:

- When the camera angle is adjusted to the upper left or upper right, the image may be slightly distorted.

- 4** Connect the wires. Loosen the screws. Push in the wires to the terminal connectors (non-polar), then tighten the screws (①).

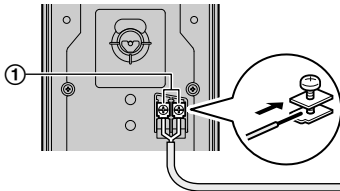

- ① – Recommended torque: 0.5 N·m {5.1 kgf·cm}
– Maximum torque: 0.7 N·m {7.1 kgf·cm}

- 5** Attach the doorphone to the mounting base.

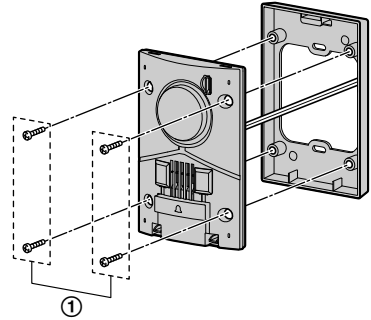

- ① Screws (accessory) × 4

When using flush mount box (option): Model No. VL-MB524

Attach the doorphone to the flush mount box.

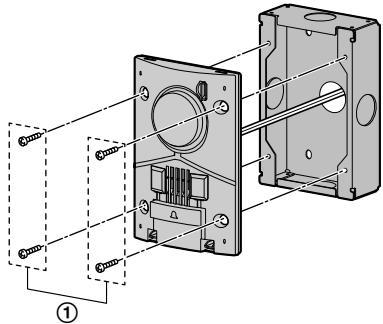

- ① Screws (accessory) × 4

- 6** Attach the front panel in the order of ① → ②.

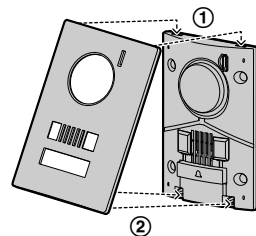

Installing the power supply unit (VL-SV75AZ, VL-MV75AZ models only)

About the installation location

- The AC cable plug is used as the main disconnect device. Ensure that the power outlet is installed near the product and is easily accessible.
- A readily accessible disconnect device shall be incorporated external to the equipment.
 - External disconnect device must be certified and have a creepage and clearance distance of 3 mm or more.

Precautions for wiring

- Make sure that the power supply unit is unplugged before performing any wiring work.
- Always connect AC or DC cables to the appropriate connector or connection terminal.
- To prevent the DC cable from disconnecting and to prevent electric shock, secure the DC cable using the cable binder (accessory) and attach the cable cover.

How to connect the AC cable and DC cable:

Connect the power supply unit (accessory), the AC cable (accessory), and a DC cable (locally procured).



① 7 mm

Front view

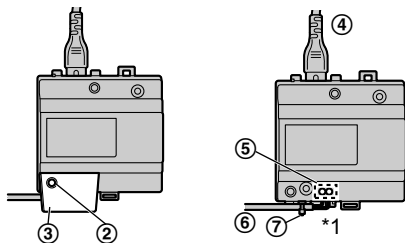

*1 Make sure that there are no core conductor wires (①) exposed outside the product.

Power supply unit (with cable cover removed)

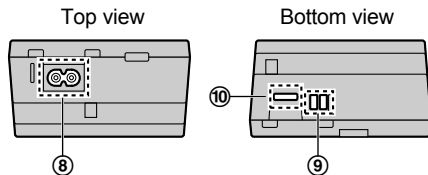

⑩ DC cable binder hole

- 1 Strip the DC cable as follows:
DC cable (①)
- 2 Remove the screw (②) and then remove the cable cover (③).
- 3 Connect the AC cable (④) (accessory) to the AC IN connector (⑧) on the top of the power supply unit. Next, connect the DC cable (⑥) (locally procured) to the DC OUT terminal (⑨) on the bottom of the power supply unit, and then secure the wires by tightening the screws (⑤).
 - Recommended torque: 0.45 N·m {4.6 kgf·cm}

⚠ CAUTION

Insert the cables firmly all the way into the connector and terminals. If the cables are not inserted all the way, heat may be generated.

- 4 Use the cable binder (⑦) (accessory) to secure the DC cable (⑥) (sheath area) to the DC cable binder hole (⑩) on the power supply unit.
- 5 Make sure to replace the cable cover (③).

Wall mounting

Attach the power supply unit to the wall securely.

① Screws (accessory) × 2

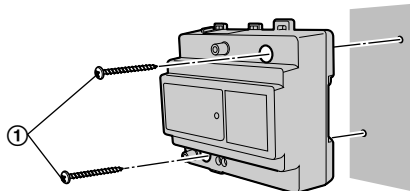

Attach to the DIN rail

Attach in the order described below so that hook (1) is positioned at the bottom.

- 1 Hang hook (2) on the DIN rail (3).
- 2 Pull and hold the lever down (4).
- 3 Secure hook (1) to the DIN rail (5).

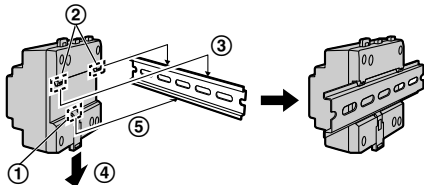

Main monitor/extension monitor installation position

About the installation position of the main monitor/extension monitor and mounting bracket

- Place the main monitor/extension monitor in a location that your eyes are the same height as the centre of the display.
- For the following reasons, leave at least 20 cm (1) of space above, below, and to the left and right sides of the main monitor/extension monitor:
 - To prevent malfunction and sound cutting out
 - To ensure to make sure the reset button (2) can be used (the reset button is on the side of the main monitor/extension monitor)

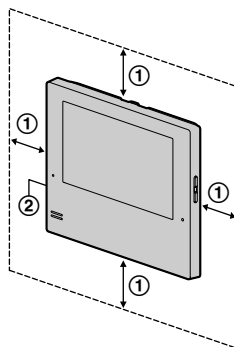

- After deciding where to install the main monitor/extension monitor, attach the mounting bracket in the location shown below.

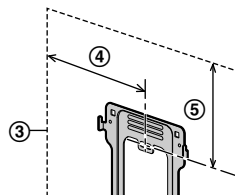

③ Main monitor/extension monitor installation position

④ 100.4 mm

⑤ 55.7 mm

Installing the main monitor/ extension monitor

- 1 Attach the mounting bracket (1) to the wall securely.
 - Install the mounting bracket on a vertical flat wall (2).

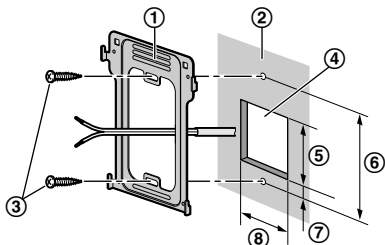

- ③ Screws (accessory) × 2
- ④ Hole in wall ⑤ 60 mm ⑥ 83.5 mm
- ⑦ 7 mm ⑧ 50 mm

2 VL-SV74/VL-MV74 models:

Connect the wires.

- Connect the wires correctly according to "Wiring schematic diagram".

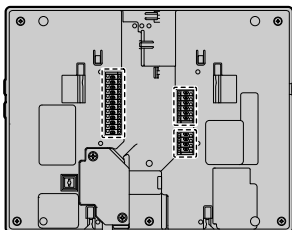

• How to make wiring connections

While pressing on the button (1) with a pointed object such as a screwdriver, insert the wire into the terminal connector (2). (To disconnect a wire, while pressing on the button (1), pull out the wire.)

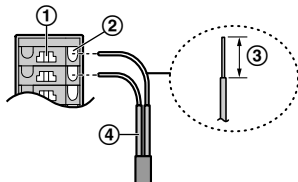

- ③ Core conductor wire at tip: 9 mm
- ④ Wiring from doorphone or other device

VL-SV75/VL-MV75 models:

Connect the DC cable and wires.

- Connect the wires correctly according to "Wiring schematic diagram".

2-1 How to connect the DC cable

- 1 Remove screw A (1) and then remove the terminal cover.
- 2 While pressing on the button (2) with a pointed object such as a screwdriver, insert the wires of the DC cable into the terminal (the DC cable of the power unit can be wired in the desired direction from the 3 depressions (3)) connectors (non-polar).
- 3 Make sure to replace the terminal cover.

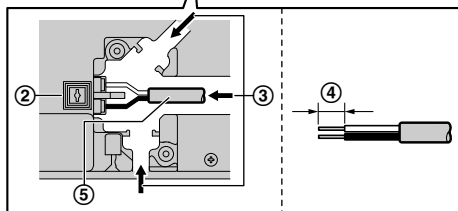
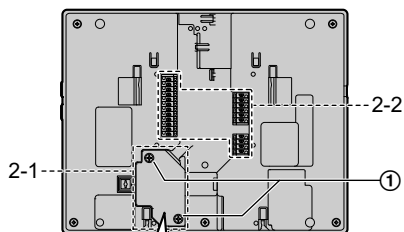

- ④ Core conductor wire at tip: 12 mm
- ⑤ Wiring from power supply unit (Example: when wiring from the right direction)

2-2 How to make wiring connections

While pressing on the button (6) with a pointed object such as a screwdriver, insert the wire into the terminal connector (7). (To disconnect a wire, pull out the wire while pressing on the button (6).)

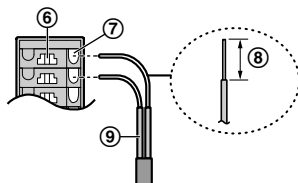

- ⑧ Core conductor wire at tip: 9 mm
- ⑨ Wiring from doorphone or other device

Important:

- Do not connect the power cable.
(Damage may occur.)

Note:

- Do not remove the terminal cover.
(Excluding VL-SV75 and VL-MV75 models.)

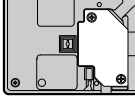

- 3** Mount the main monitor/extension monitor to the mounting bracket.

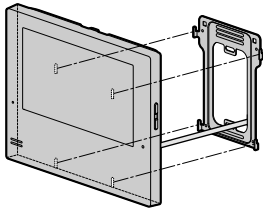

- 3-1 Line up the tab on the bottom of the bracket with the groove on the main monitor/extension monitor.

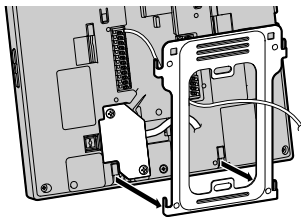

- 3-2 Line up the tab on the top of the bracket with the groove on the main monitor/extension monitor, and push the main monitor/extension monitor down until it is secure.

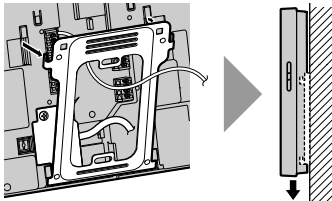

**Notes about electrical wiring (for VL-SV75/
VL-MV75 models)**

[When wiring from bottom]

Make sure not to pinch the wires (as shown below) on the mounting bracket when installing.

- Do not forcibly attach to the mounting bracket.

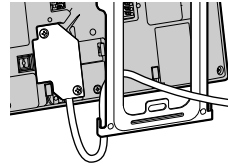

Panasonic Corporation

1006, Oaza Kadoma, Kadoma-shi, Osaka 571-8501, Japan

<http://www.panasonic.com>

© Panasonic Corporation 2019



PNQX8981ZA

PNQX8981ZA C1119MM0