

Panasonic

Information Guide

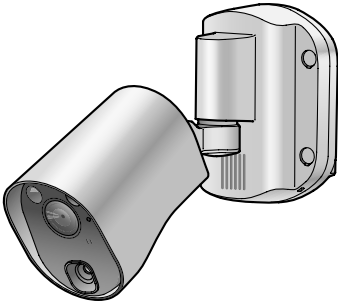

Wireless Sensor Camera Model No. **VL-WD812AZ**

Table of Contents

Introduction	2
General information	2
For your safety	2
Important safety instructions	3
For best performance	3
Other important information	3
Sensor operations	4
Controls	6
Cleaning	7
Specifications	7

Thank you for purchasing a Panasonic product.

Please read this manual before using the product and save it for future reference.

**This product is not designed to be used for the prevention of property loss or intrusions.
In no event shall Panasonic be liable to any loss or damage arising out of the use of this product.**

Installation Guide is supplied separately.

Introduction

This product is an additional product designed to be used with the following Panasonic Video Intercom Systems.

– VL-SWD501AZ/VL-SWD501UAZ (Main monitor station: VL-MWD501BX)

(The corresponding models are subject to change without notice.)

You must register this product with your Video Intercom System before it can be used.

- For registration information, refer to the Installation Guide of this product or the Operating Instructions of the Video Intercom System.
- This manual only covers the information and cautions required for the preparation and initial use of the product. For detailed information on how to operate the product, refer to the Operating Instructions of the Video Intercom System.
- The illustrations in the supplied manual(s) may vary slightly from the actual product.
- See the Installation Guide for information about accessories.

Product names used in this manual

Model No.	Product name	Name in this manual
VL-WD812AZ*1	Wireless sensor camera	Camera
VL-MWD501BX	Main monitor station	Main monitor
VL-WD613AZ*1	Wireless monitor station	Sub monitor

*1 The product label reads as follows: VL-WD812EX/VL-WD613BX

General information

- In the event of problems, you should contact your equipment supplier in the first instance.

For your future reference

We recommend keeping a record of the following information to assist with any repair under warranty.

Serial No.	Date of purchase
(found on the rear of the product)	
Name and address of dealer	

Attach your purchase receipt here.



For your safety

To prevent severe injury and loss of life/property, read this section carefully before using the product to ensure proper and safe operation of your product.



Preventing fire, electric shock and short circuits

- Use only the power source marked on the product. If you are not sure of the type of power supplied to your home, consult your dealer or local power company.
- Use only the specified power supply unit and AC cable.
- Do not attempt to disassemble or modify this product. Contact an authorised service centre for repairs.
- Never touch the power supply unit and AC cable with wet hands.
- Do not touch the power supply unit and AC cable during an electrical storm.
- Never spill liquids on the power supply unit and AC cable (the power supply unit and AC cable are for indoor use only). Do not directly spray the camera with water from a hose or other objects. Never spill any liquid inside the product.
If the power supply unit, AC cable, or internal parts of the camera become wet, unplug the product and contact an authorised service centre.
- Never put metal objects inside the product. If metal objects enter the product, unplug the product and contact an authorised service centre.

- Do not perform any actions (such as fabricating, twisting, stretching, bundling, forcibly bending, damaging, altering, exposing to heat sources, or placing heavy objects on the power cable) that may damage the power cable. Using the product with a damaged power cable may cause electric shock, short circuits, or fire. Contact an authorised service centre for repairs.
- Unplug the product if the product emits smoke, an abnormal smell or makes unusual noise, or if the product has been dropped or physically damaged. These conditions can cause fire or electric shock. Confirm that smoke has stopped emitting and contact an authorised service centre.

Preventing accidents and injuries

- Do not pull or hang off the product or power cable. Pulling out the power cable may cause electric shock or cause the camera to fall down, resulting in injury.
- Do not drop the product or expose it to a strong impact. To prevent the product from falling, securely fix the safety wire to the product and a wall.
- The sensor range cap may become a choking hazard. Keep it out of reach of children. If you suspect a child has swallowed the sensor range cap, seek medical advice immediately.



Preventing fire and electric shock

- Do not use the product in areas that are exposed to moisture, steam, or oily smoke, or areas that have excessive dust.

Preventing accidents and injuries

- Do not put your ear(s) near the speaker, as loud sounds emitted from the speaker may cause hearing impairment.
- Do not look directly at the LED lights when they are lit. Failure to do so may cause damage to eyes.

Important safety instructions

When using this product, basic safety precautions should always be followed to reduce the risk of fire, electric shock, or personal injury.

1. Use only the power supply unit and AC cable indicated in this manual.

SAVE THESE INSTRUCTIONS

For best performance

- Do not allow the lens cover (①) or the heat sensor (②) to become scratched or dirty. (This may cause image quality to be reduced, incorrect detections, malfunctions, or damage to the lens cover and heat sensor.)
- Do not expose this product to direct sunlight or other forms of powerful light such as halogen lights for long periods of time. (This may damage the image sensor.)

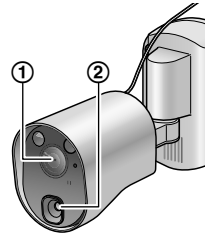

Other important information

Privacy and rights of portrait

See the Installation Guide for the camera or the Operating Instructions of the Video Intercom System for more information.

Camera image quality

- Camera images may have the following characteristics.
 - Colours in images may differ from the actual colours.
 - When there is light at the back of the object, faces may appear dark.
 - Image quality may be reduced in dark locations.
 - Images may appear hazy when there are outdoor lights in use.
- Effect of brightness and distance on image quality: Distinguishing faces is difficult in the following situations.
 - When the person is too far (over approx. 3 m) from the camera even when the surrounding area is bright. (Depending on the viewing angle or the conditions when images were viewed, such as when there are shadows or backlighting, faces may not be distinguishable even when the person is within 3 m of the camera.)
 - In the late afternoon and at night, or other times when the surrounding area is dark. (This may reduce image quality.)
 - When people are moving (which causes blurring) in front of the camera.

Repairing, transferring, disposing, or returning the product

Requesting repairs for the product

- Note that the settings of the camera may be altered or changed to the default settings during repairs.

Note for product disposal, transfer, or return

- Use the main monitor to perform the [Initialize settings] setting for the camera. (→ See the Operating Instructions of the Video Intercom System.)
Settings are returned to their default values when initialization is performed.

Information on Disposal in other Countries outside the European Union



These symbols are only valid in the European Union. If you wish to discard these items, please contact your local authorities or dealer and ask for the correct method of disposal.

Others

- It is prohibited to disassemble or modify this product. Contact the dealer where you purchased this product for repair.

- When power fails, this product cannot be used.
- Panasonic may not be liable for damages due to external factors such as power failures.
- Adjust the speaker volume settings ([Sensor trigger sound], [Warning sound], and [Owner's voice volume]) appropriately so that sound from the camera does not make a disturbance in the area around the camera. (→ See the Operating Instructions of the Video Intercom System.)
- When the camera is no longer used.
 - When the camera's registration is cancelled with the main monitor, disconnect the camera's power supply in order to prevent incorrect operations. (→ See the Operating Instructions of the Video Intercom System for information about cancelling the camera's registration.)
 - Remove the camera from its mounted location when it is no longer in use. (Contact our service personnel for information about removing the camera.)

Sensor operations

The camera has 2 sensors: the motion detection sensor and the heat sensor.

Please read the following information about the camera's motion detection sensor and heat sensor before deciding where to mount the camera.

Sensor characteristics and detection range

	Motion detection sensor	Heat sensor
Detection method	The camera detects changes in the images being displayed. <ul style="list-style-type: none">● The camera detects changes in the brightness levels of moving objects.	The camera detects temperature differences of objects in the images being displayed. <ul style="list-style-type: none">● The heat sensor uses infrared rays to detect temperature differences within its range that are emitted naturally by people, animals, etc.
Main characteristics	Easily detects movement in the daytime or when it is bright. <ul style="list-style-type: none">● Movement may be incorrectly detected when the moving object and the background have a similar colour.● Movement may be incorrectly detected when there are sudden changes to the overall brightness levels such as when external lights are used.	Easily detects when there is a big difference between the temperatures of objects and the surrounding environment, such as in winter or late at night. <ul style="list-style-type: none">● The sensor cannot easily detect when there is no difference between the temperatures of objects and the surrounding environment, such as in summer or during the daytime.● If the camera is mounted facing a road, the sensor may detect incorrectly due to interference caused by the heat from passing cars.

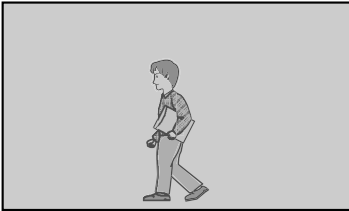
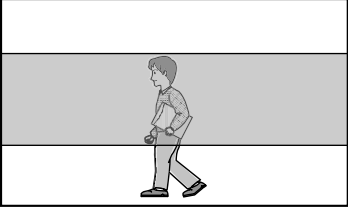
	Motion detection sensor	Heat sensor
Detection range	<p>Entire viewed image</p>  <ul style="list-style-type: none"> The detection range can be reduced. (See the [Motion detection range] setting in the Operating Instructions of the Video Intercom System.) 	<p>Part of viewed image (grey area)</p>  <ul style="list-style-type: none"> The detection range can be changed. (See the information about adjusting the detection range in the Installation Guide.)

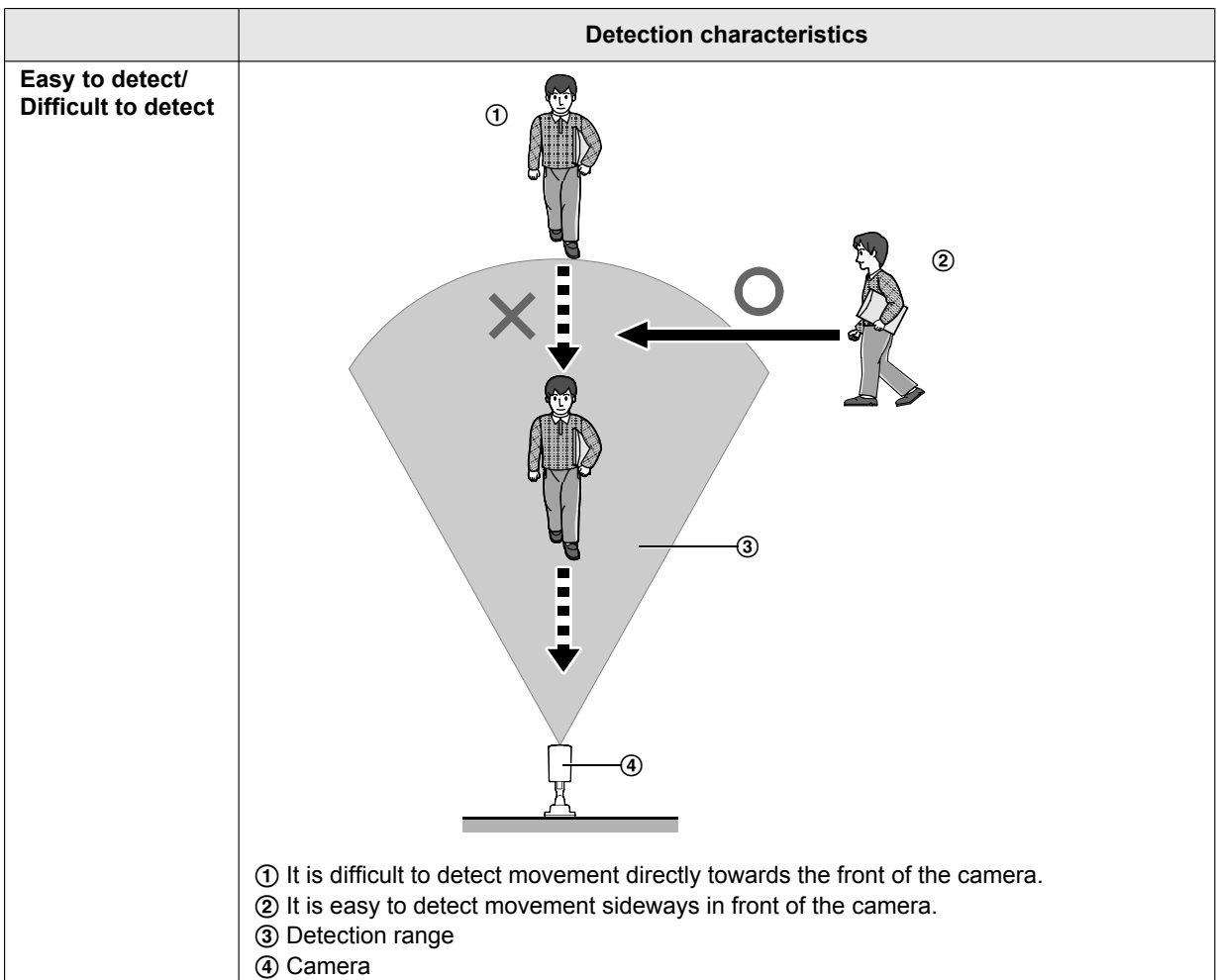

- The motion detection sensor and heat sensor are not designed to be used in situations that require high reliability. We do not recommend use of the motion detection sensor and heat sensor in these situations.
- Panasonic takes no responsibility for any injury or damages caused by use of the motion detection sensor and heat sensor.

Sensor operating range

In the default settings, the motion detection sensor and heat sensor operate in the following way depending on changes to the brightness levels.

Daytime or when it is bright

At night or when it is dark

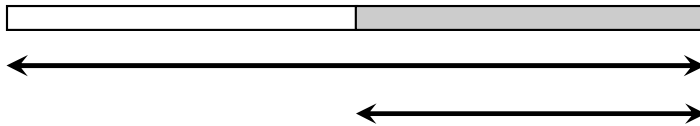

Motion detection sensor

Heat sensor

- The brightness level is automatically determined by the camera when viewing images. A timer can be configured to switch the modes between day and night modes at specified times. (See the [Day and night switch] setting in the Operating Instructions of the Video Intercom System.)
- The settings can be configured to match the installation environment by only operating the motion detection sensor and heat sensor at certain times, for example only during the day or only at night. (See the [Heat sensor detection] and [Motion detection] settings in the Operating Instructions of the Video Intercom System.)

Controls

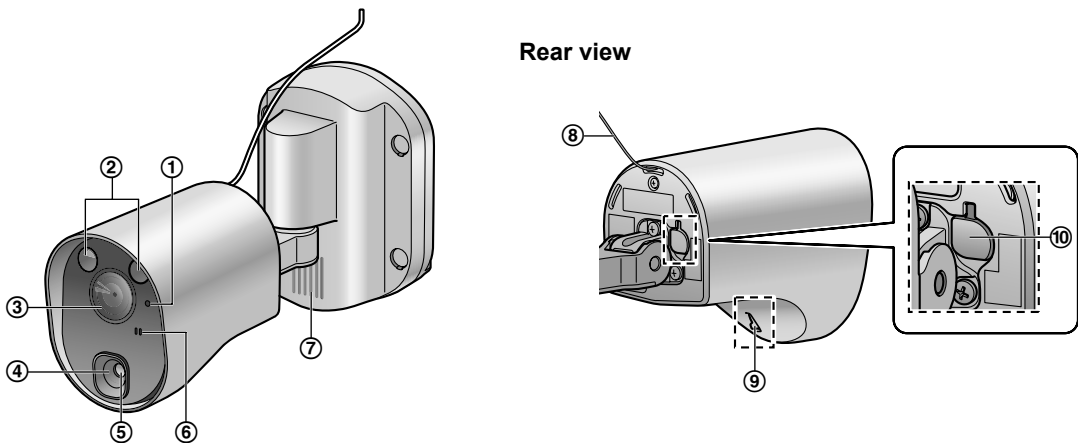

① **Indicator lamp** (See the following explanation.)

② **LED lights**

- Automatically lights when it is dark and the camera is monitoring or when sensors are operating. (The LED lights are designed to be used as warning lights for intruders and are not meant to be used for illumination.)

③ **Lens cover**

- Contains a lens and a brightness sensor. (See the following explanation.)

④ **Sensor range cap (standard type)**

- 4 types of lens caps (accessories) can be fitted as required. (→ Installation Guide)

⑤ **Heat sensor**

- Detects changes in temperature. (→ page 4)

⑥ **Microphone**

⑦ **Speaker**

⑧ **Safety wire**

⑨ **Heat sensor lever**

- Used to change the angle of the heat sensor. (→ Installation Guide)

⑩ **Register button (behind the register button cover)**

- The register button is located behind the register button cover. Used when registering the camera to the main monitor. (→ Installation Guide)

Brightness sensor

Determines whether to light the LED lights by detecting the brightness of the surrounding area.

Indicator lamp

After the camera has been registered to the main monitor, you can check the camera's status and the wireless signal status from the main monitor by checking the status of the indicator lamp.

Indicator display		Camera's status		
Transmission status	Flashing green (fast)	A sensor has been triggered and the camera is calling the main monitor.		
	Flashing green (slow)	The camera is transmitting data to the main monitor.		
Signal status (during standby)	Lit green		Strong	Indicates the signal status from the main monitor. <ul style="list-style-type: none">• We recommend installing the camera in an area where the status indicator is strong (when the indicator is lit green).
	Lit orange		Weak	
	Lit red			
	Flashing red	Transmissions cannot be sent because there is no signal (out of range).		

- Depending on how [Indicator lamp] is configured, the indicator may always be off or only be lit when transmitting (when monitoring or talking) with the main monitor. (See the [Indicator lamp] setting in the Operating Instructions of the Video Intercom System.)

Cleaning

In order to prevent incorrect sensor detections, disconnect the power from the camera when cleaning the camera.

Wipe the camera with a soft cloth.

- When the camera is excessively dirty, wipe it with a slightly damp cloth.

Important:

- **Do not directly spray the camera with water from a hose or other objects.** (There is a risk of fire or electric shock if water enters inside the camera.)
- **Do not use any cleaning products that contain strong or weak detergents, alcohol, polish powder, powder soap, benzene, thinner, wax, petroleum, or boiling water. Also do not spray the product with insecticide, glass cleaner, or hair spray. This may cause a change in colour or quality of the camera.**

Specifications

Power source	Power supply unit (VL-PS241) 24 V DC, 0.4 A
Power consumption	During standby: approx. 1.5 W During operation: approx. 4.5 W (when the LED lights are not lit), approx. 8 W (when the LED lights are lit)
Dimensions (mm) (height × width × depth)	Approx. 160×118×290 (when the camera is front facing and including the wall mount bracket)
Mass (weight)	Approx. 960 g
Installation method	Wall mount (wall mount bracket supplied)
Operating environment	Ambient temperature: approx. -20 °C to +50 °C Relative humidity (non-condensing): up to 90 %
Transmitting range	Approx. 100 m (line-of-sight distance from the main monitor)
Frequency range	1.88 GHz to 1.90 GHz
Image sensor	0.3 M pixel CMOS
Minimum illuminance required	1 lx*1
Focal length	Fixed (0.4 m - infinity)
Angular field of view (camera angle)	Horizontal: approx. 53°, vertical: approx. 41°

Sensor detection method	Pyroelectric infrared sensor (heat sensor) and motion detection
Sensor detection range	<ul style="list-style-type: none"> Heat sensor (when the surrounding temperature is approx. 20 °C) Horizontal: approx. 63°, vertical: approx. 20°, detection range: approx. 5 m Motion detection sensor Horizontal: approx. 53°, vertical: approx. 41°
Lighting method	2 white LED lights*2
IP rating	IP54*3
Adjustable mounting angles	Horizontal: ±90°, vertical: facing forward - facing down approx. 60° (adjustable when mounting)
Heat sensor adjustable angles	Manually adjustable to 2 angles

Power supply unit (VL-PS241) (indoor use only)

Power source	Input: 220-240 V AC, 0.2 A, 50/60 Hz Output: 24 V DC, 0.6 A
Dimensions (mm) (height × width × depth)	Approx. 104×100×54 (excluding protruding sections)
Mass (weight)	Approx. 215 g
Operating environment	Ambient temperature: approx. 0 °C to +40 °C Relative humidity (non-condensing): up to 90 %

*1 The minimum illuminance required when the camera's [Brightness] setting is set to [+3].

*2 Approx. 8.5 lx when 3 m in front of the camera, and approx. 4 lx when 3 m away and 20° to the left or right of the camera.

*3 Water resistance is only assured if the camera is installed correctly according to the instructions in the Installation Guide, and appropriate water protection measures are taken. Do not install the camera in areas directly exposed to water or rain.

Note:

- Design and specifications are subject to change without notice.
- Names, company names, product names, software names, and logos mentioned in this manual are trademarks or registered trademarks of the companies concerned.

Panasonic System Networks Co., Ltd.
1-62, 4-chome, Minoshima, Hakata-ku, Fukuoka 812-8531, Japan
<http://www.panasonic.net/>

© Panasonic System Networks Co., Ltd. 2014



PNQX71 03ZA

PNQX7103ZA C0814MM0